

I-Meet

Nikolas Chachamis - CSR Las Mobili



La collezione si caratterizza per:

01/ Gambe in acciaio cromato lucido o verniciate nero opaco. **02/** Postazione relatore a cattedra singola e doppia. **03/** Leggio. **04/** Contromobile con basamento metallico. **05/** Modulo top access elettrificato e non con apertura basculante. **06/** Wire manager sottopiano. **07/** 4 finiture di legni e 2 tinte unite per i piani. **08/** 1 finitura in vetro.

This collection is characterised by:

01/ Polished chrome-finished steel legs or matt black painted legs. **02/** Speakers' place with single or double desk. **03/** Podium. **04/** Matching furniture with metal base. **05/** Wired and non-wired top access module with tilting opening. **06/** Under-the-top wire manager. **07/** 4 wood finishes and 2 plain colours for the worktops. **08/** 1 glass finish.

La collection est caractérisée par :

01/ Pieds en acier chromés polis ou peints en noir mat. **02/** Poste de l'orateur à table single ou double. **03/** Pupitre. **04/** Contre-meuble avec base en métal. **05/** Module top-access électrifié ou non électrifié avec ouverture basculante. **06/** Système de gestion des câbles sous le plateau. **07/** 4 finitions en bois et 2 couleurs pleins pour les plateaux. **08/** 1 finition en verre.







cod. 12



cod. NR 03

cod. 56



↑
Tavolo riunioni
in formato
quadrato con top
access centrale.
Square meeting
table with
central top
access.
Table de réunion
carré avec top
access central.

Tavoli riunioni in vari formati, variamente aggregabili fino alle grandi composizioni. La riduzione degli appoggi e la sezione snella delle gambe conferiscono grande leggerezza e stabilità ad ogni composizione, permettendo un perfetto utilizzo su ogni lato.

Meeting tables in different formats that can be combined in a number of ways up to large compositions. The reduction of supporting elements and the slender legs add lightness and stability to each composition, allowing perfect use on all sides.

Tables de réunion dans formats différents, qui peuvent être combinées pour obtenir de grandes compositions. La réduction des appuis et la section élancée des pieds donne une grande légèreté et stabilité aux compositions, pour une utilisation parfaite sur tous les côtés.



cod. 30

→
L'angolo è
caratterizzato
dallo smusso che
segue la posizione
della gamba.
Corners are
characterised
by the bevelling
that mirrors the
leg position.
Le coin est
caractérisé par
le biseau qui suit
la position de
la jambe.



Nelle grandi composizioni è assicurato un ottimale cablaggio in ogni posizione, grazie a top access lineari e ampi Wire Manager per le salite.

In large compositions, optimal wiring is available in all positions, thanks to linear top access openings and large Wire Managers for upward wiring.

Dans les grandes compositions, le câblage optimal est assuré dans n'importe quelle position, grâce au top access linéaire et aux amples systèmes Wire Managers pour les montées des câbles.

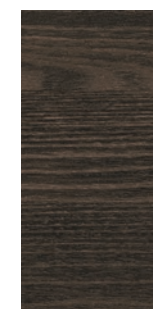

cod. 52







→
 Il cablaggio
 è facilmente
 accessibile e
 perfettamente
 nascosto.
 Wiring is easily
 accessible
 and completely
 hidden.
 Le câblage est
 facilement
 accessible et
 parfaitement
 caché.



In ambienti conferenza o formazione la postazione dei relatori assume un valore comunicativo e tecnico ineccepibile. Il livello estetico è adeguato alla qualità dell'ambiente, le dotazioni tecnologiche soddisfano le funzioni specifiche di una relazione in presenza o online.

Dans les salles de conférence ou de formation, la position des intervenants acquiert une valeur communicative et technique impeccable. Le niveau esthétique est conforme à la qualité de l'environnement, les équipements technologiques répondent aux fonctions spécifiques des relation en face à face ou en ligne.

In conference or training environments, the speakers' seat features an impeccable communicative and technical value. The aesthetic level is up to the quality of the environment, with technological equipment that meet specific functions of both face-to-face and online relationships.







←
L'angolo smussato
mantiene lo stesso
allineamento della
gamba.
Bevelled corners
maintain the
alignment with the
legs.
Le coin arrondi
maintient le même
alignement du pied.

**I piani di lavoro in cristallo
retro laccato conferiscono
grande eleganza al tavolo
riunioni e si pongono
in contrapposizione col
modulo tecnologico
centrale in legno.
Un ulteriore livello di pregio
di materiali ed abbinamenti
per un meeting moderno ed
elegante.**

Back-lacquered glass
worktops give great
elegance to the meeting
table and create contrast
with the wood of the
central technical module.
An additional level of
quality in materials and
combinations, for modern
and elegant meetings.

→
Tavolo riunioni
quadrato con
modulo tecnico
centrale.
Square meeting
table with
technical
central module.
Table de réunion
carré avec
module technique
central.



cod. 10

Les plans de travail en
verre rétro-laqué donnent
une grande élégance à
la table de réunion et
contrastent avec le module
technologique central en
bois. Un ultérieur niveau de
prestige dans les matériels
et les combinaisons pour
des rencontres modernes et
élégants.



Tavoli riunione

Meeting tables | Tables de réunion

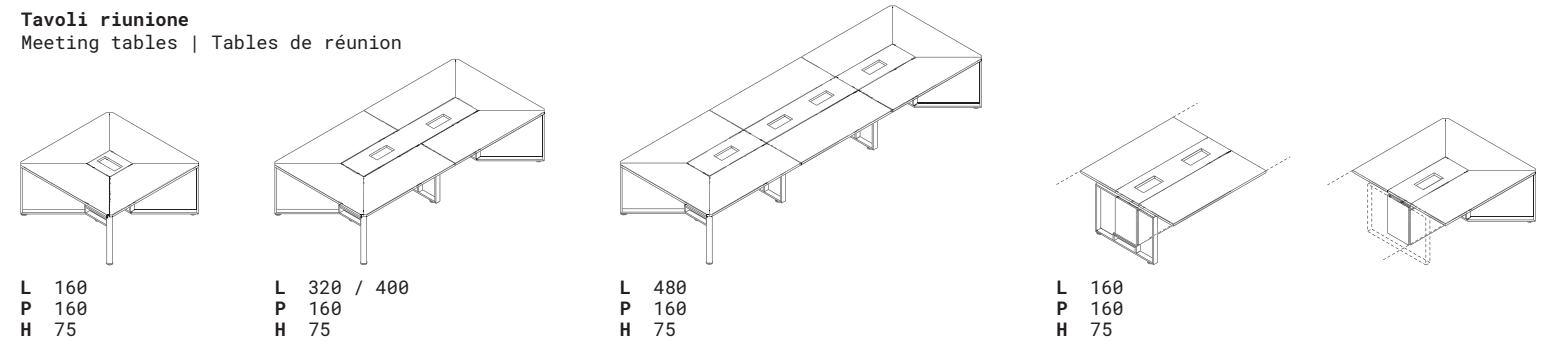

L 160
P 160
H 75

L 320 / 400
P 160
H 75

L 480
P 160
H 75

L 160
P 160
H 75

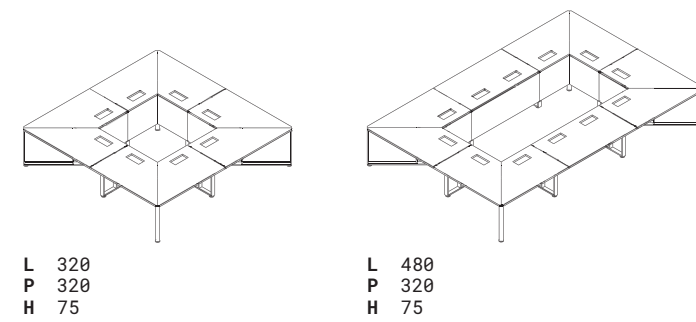

L 320
P 320
H 75

L 480
P 320
H 75

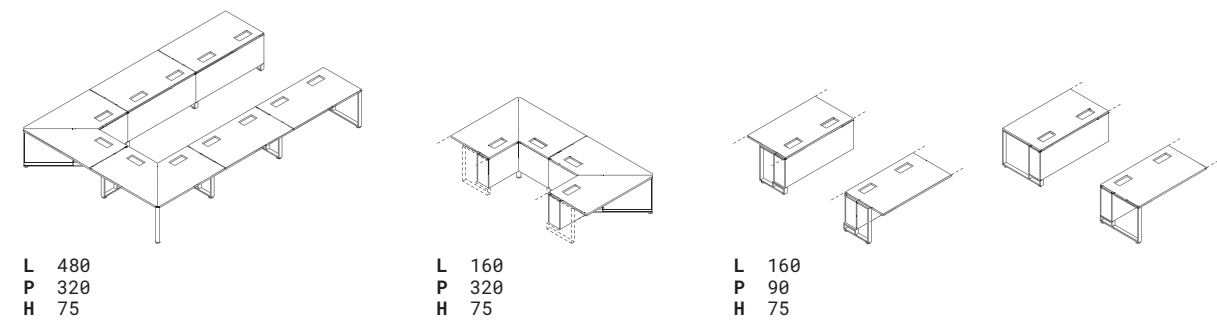

L 480
P 320
H 75

L 160
P 320
H 75

L 160
P 90
H 75

Complementi di arredo

Accessories | Meubles de rangements

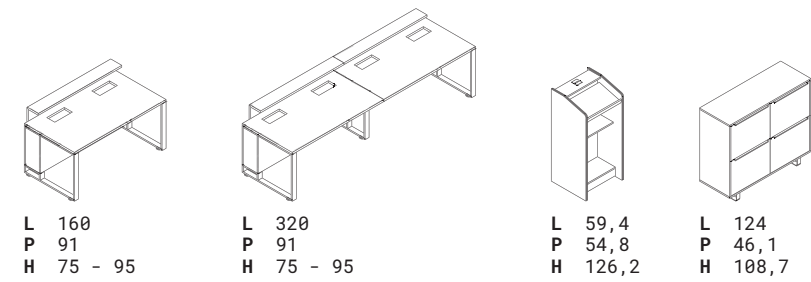

L 160
P 91
H 75 - 95

L 320
P 91
H 75 - 95

L 59,4
P 54,8
H 126,2

L 124
P 46,1
H 108,7